

SPECIFICATIONS

1. UNDER FENCE PLINTH (UFP) CONCRETE GRADE TO BE N60. RIGID FORMWORK & INTENSE CONCRETE COMPACTION IN ACCORDANCE WITH AS 3600 IS REQUIRED FOR CASTING EACH UFP.
2. UFP STD NOT TO BE USED WITHIN 1 Km OF THE COAST.

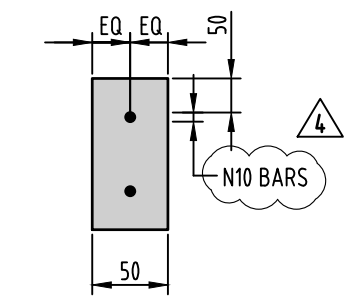

SECTION A-A
SCALE 1:10

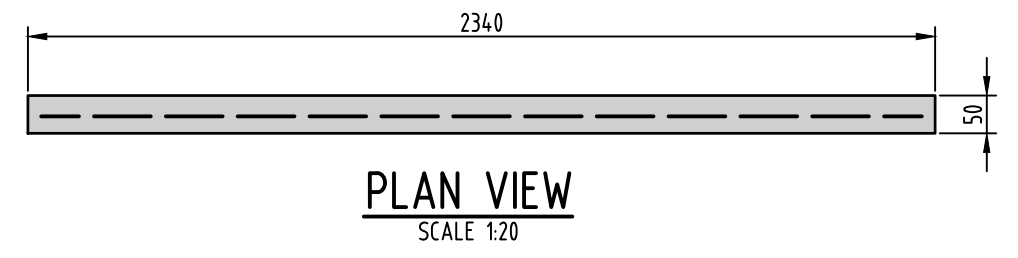

PLAN VIEW
SCALE 1:20

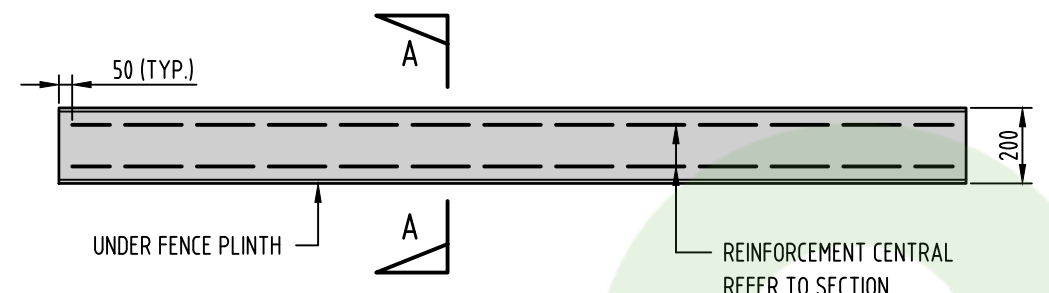

ELEVATION VIEW
SCALE 1:20

STANDARD UNDER FENCE PLINTH (UFP STD) SCALE 1:20

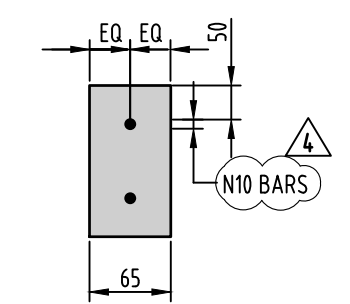

SECTION B-B
SCALE 1:10

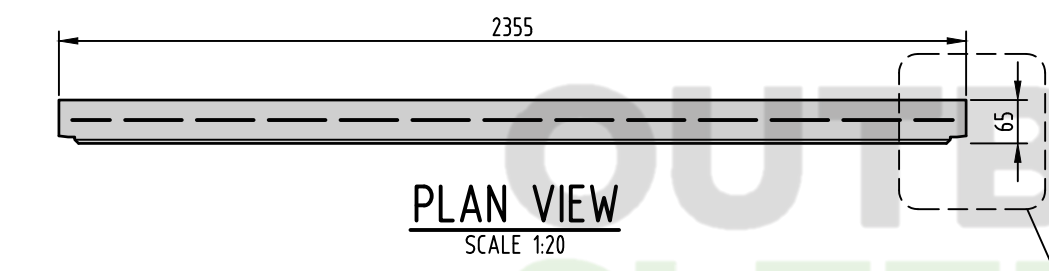

PLAN VIEW
SCALE 1:20

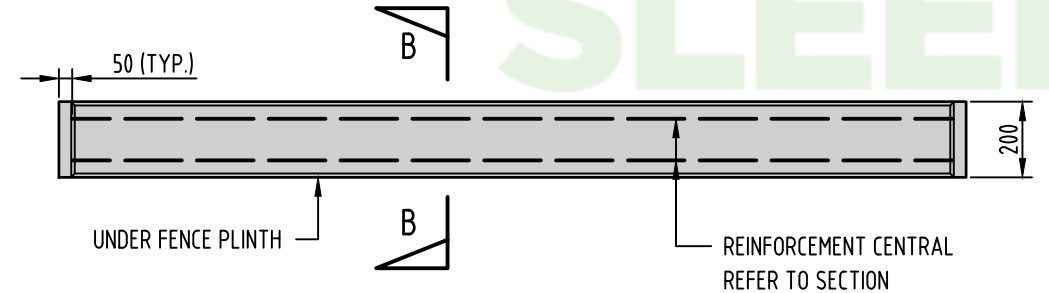

ELEVATION VIEW
SCALE 1:20

HEAVY DUTY UNDER FENCE PLINTH (UFP HD) SCALE 1:20

CONSTRUCTION
ISSUE

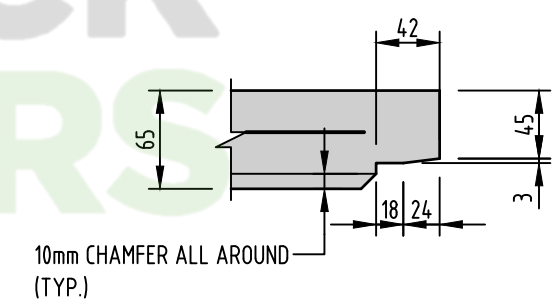

DETAIL
SCALE 1:5

| REV. | DATE | DESCRIPTION | DRAFT | ENG. | CHK. |
|------|----------|----------------------|-------|------|------|
| 0 | 10.05.19 | CONSTRUCTION ISSUE | AA | CL | CL |
| 1 | 09.07.19 | CONSTRUCTION ISSUE | AA | CL | CL |
| 2 | 22.06.20 | CONSTRUCTION ISSUE | AA | CL | CL |
| 3 | 03.07.20 | CONSTRUCTION REISSUE | AA | CL | CL |
| 4 | 04.09.20 | CONSTRUCTION REISSUE | AA | CL | CL |

WGA

WALLBRIDGE GILBERT
AZTEC

60 Wyatt Street, Adelaide
South Australia 5000
Telephone 08 8223 7433
Email adelaide@wga.com.au

CONCRETE SLEEPERS
OUTBACK SLEEPERS AUSTRALIA P/L

UNDER FENCE PLINTH

| | |
|------------------|----------------|
| A3 | DRAWING NUMBER |
| Design C.LINDNER | Job Number |
| Drawn A.ARIEF | Sheet No. Rev. |
| © WAD150933 | S04 4 |